



## T-Touch Connect Solar









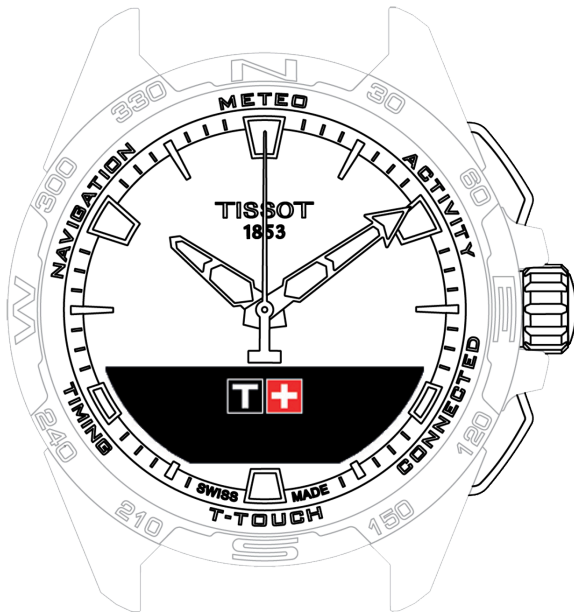

[Home](#)

# Home

Congratulations on having chosen a watch made by Tissot™, a Swiss company founded in Le Locle in 1853 and still based there today. Your watch has been made with the greatest of care, using fine-quality materials and components, and is protected against shocks, temperature fluctuations, water and dust.



-  SIGN IN
-  Clock
-  METEO (Weather)
-  ACTIVITY
-  CONNECTED
-  T-TOUCH
-  TIMING (Timing and Alarm)
-  NAVIGATION



## SIGN IN

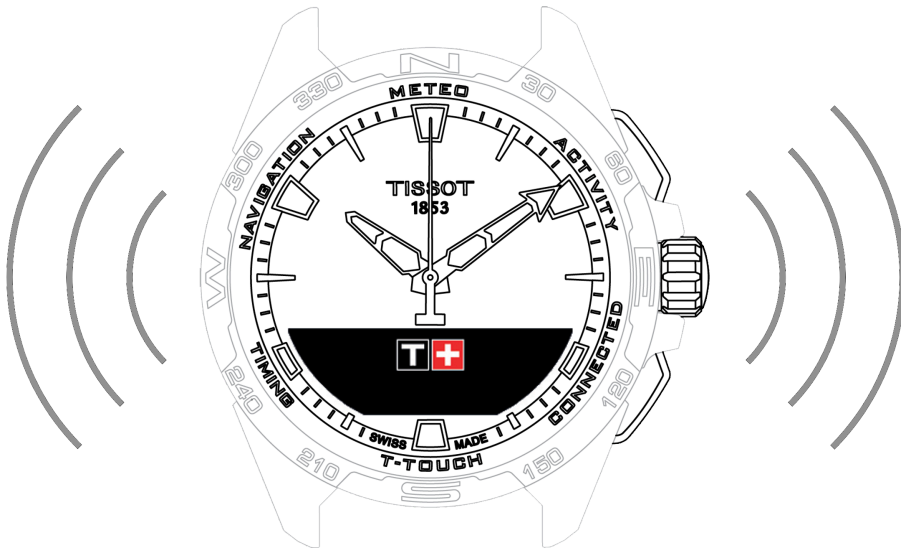

Charging



Turning the watch on



Using the T-Touch Connect Solar paired with a smartphone



Using the T-Touch Connect Solar unpaired with a smartphone



Reconnecting the watch to the phone



## Charging

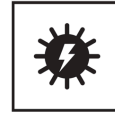

### Additional information

- Cordless charger
- Solar energy



## Cordless charger

Do not use a USB adapter (not supplied) that provides power in excess of 15 Watts.

Do not use a cable or connector that is kinked, twisted, damaged or broken.

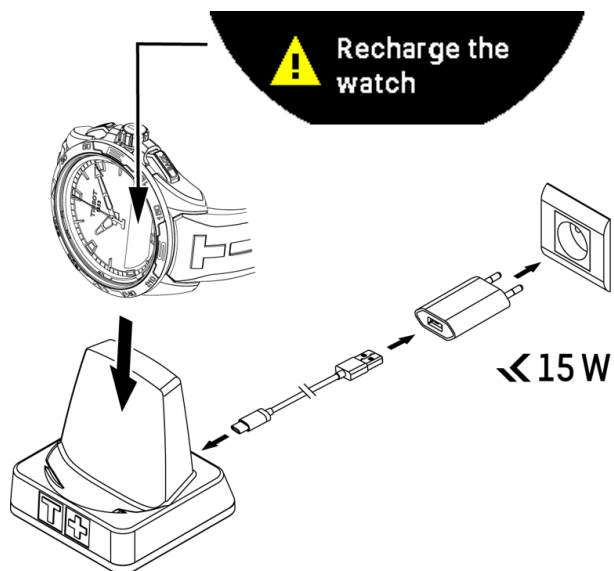

The first time you use your T-Touch Connect Solar, we recommend charging it with the T229 charger supplied, being careful to position the T-Touch Connect Solar correctly on its charger and checking that the "Charging" indicator is visible on the MIP screen.

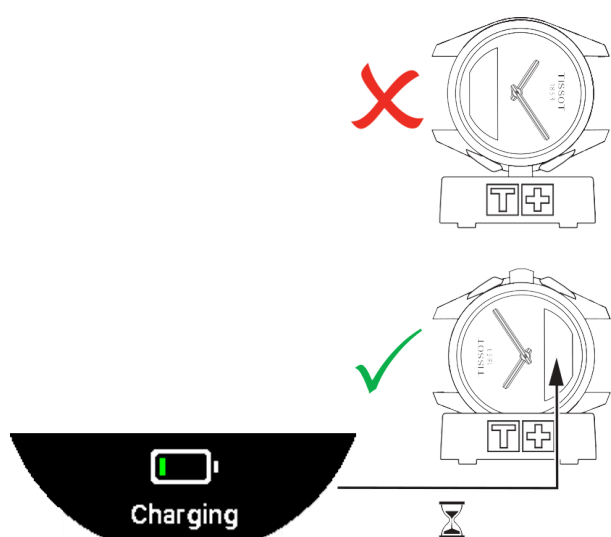

When placed on the T229 cordless charger, the T-Touch Connect Solar charges fully in under 4 hours.

This cordless power supply is compliant with circuit PS1 as per standard EN 62368-1.

## 1st charge

- Once the T-Touch Connect Solar battery is charged, briefly press the crown to select the watch language.



- Confirm your choice by briefly pressing the crown. You will be offered two watch operating options: paired to a smartphone, or non-paired.



## Solar energy

As its name indicates, the T-Touch Connect Solar uses light, especially sunlight, to recharge its battery automatically and naturally. This has the advantage of prolonging the watch's operating time.

### INFO

Please note: Avoid close exposure ( $\leq 20$  cm) of the watch to any light source. In no circumstances should you do this in an attempt to make the battery charge faster.



## Turning the watch on

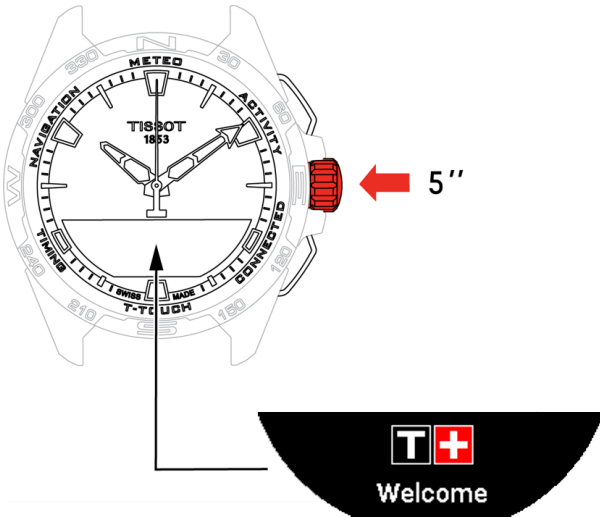

- Press the crown for 5 seconds, until the MIP screen lights up.



## Using the T-Touch Connect Solar paired with a smartphone

Only paired mode provides access to all of the T-Touch Connect Solar’s functions.

Download the T-Touch Connect Solar app to the smartphone, and follow the connection information.



The T-Touch Connect Solar’s MIP screen will display:

### "PAIR WITH PHONE?"

- Using the crown, select "YES".



### "Install the Tissot app."

- Open the T-Touch Connect Solar app on the smartphone.



### "Pair with T-Touch XXX"

- The app will automatically be paired with the closest watch, and display the "PAIRING CODE". If the code cannot be seen on the watch, or if the code displayed on the watch is different to that displayed on the app, click on "CANCEL", and start over.

#### ! INFO

Note: This is not a verification step like the following one, but it enables you to select the right watch if there are several in the vicinity.



## "PAIRING CODE"

- Confirm the pairing code on the T-Touch Connect Solar MIP screen and in the T-Touch Connect Solar app.
  - NB: you only have 30 seconds to perform this action before the pairing process times out.

## "SET PASSWORD?"

1. Up to version 6.2, use the crown to choose whether you want to secure the watch with a password. Activating a password ensures that:
  - The content of the notifications received is not displayed on the watch, in order to safeguard your privacy;
  - The watch menus are not accessible.

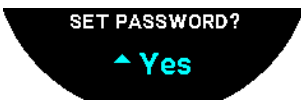

2. To set a password, select "Yes".

## "ENTER CODE"

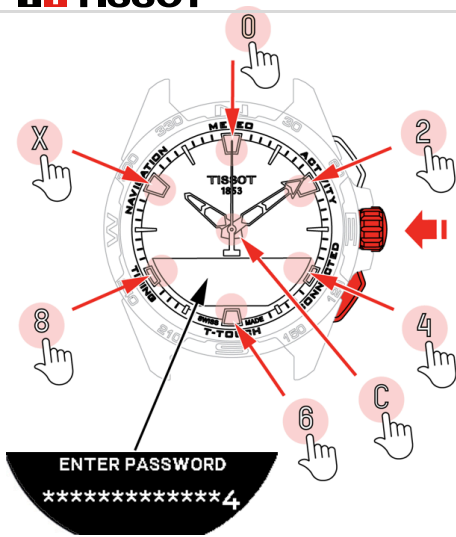

1. Use the touchpads to create the password, each zone corresponds to a character: 0, 2, 4, C, 6, 8 and X.

- NB: minimum 6 digits, maximum 14.

2. Once you have entered the password, confirm using the crown. You can go back at any time using the BACK push-button.

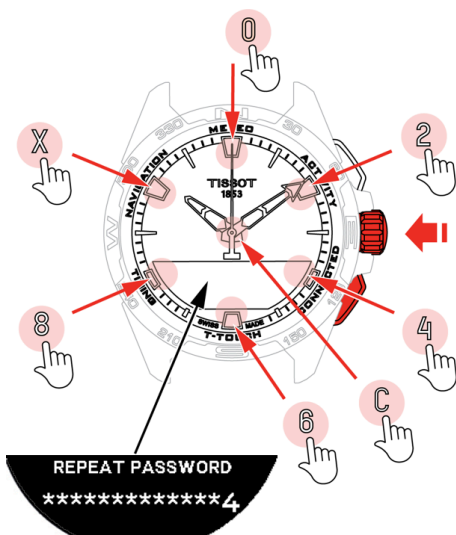

3. Re-enter the password, then confirm using the crown.

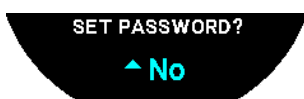

4. To opt out of setting a password, select "No" and proceed to the next step.
  - "Setting complete" will appear, meaning that the installation has been successfully completed.
  - The hands are positioned to the time, and the watch is automatically locked.
5. If you receive an error when attempting to pair your watch with the Tissot T-Connect app, select the "Retry" option to restart the process.
6. If the problem persists, follow the steps below:
  - i. Uninstall the Tissot T-Connect app.
  - ii. Reinitialise your watch (BACK > "CANCEL" push-button or T-TOUCH menu / SETTINGS / System / Restore to factory settings).
  - iii. From your watch's "Home" screen, press the crown.
  - iv. Activate Bluetooth on your smartphone.
  - v. Delete your watch from the Bluetooth settings on your smartphone.
  - vi. Activate your smartphone's internet connection.
  - vii. Install the latest version of the Tissot T-Connect app.
  - viii. Launch the app, and sign into your account to restart the process.



## Using the T-Touch Connect Solar unpaired with a smartphone

The T-Touch Connect Solar's MIP screen will display:

### "PAIR WITH PHONE?"

- Using the crown, select "No".

### "SET PASSWORD?"

1. Using the crown, choose if you want to secure the watch with a password. Activating the password ensures the watch menus cannot be accessed.

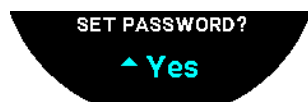

2. To define a password, select "Yes".

### "ENTER PASSWORD"

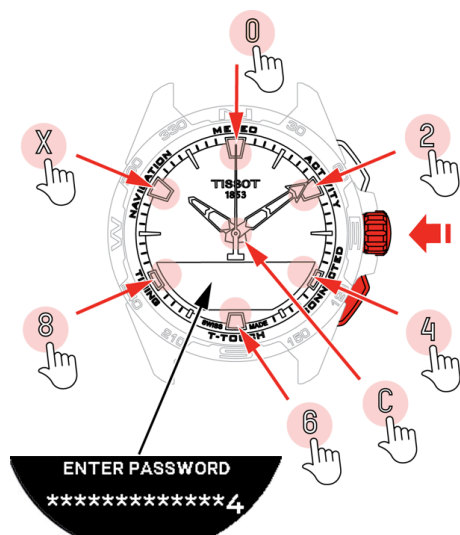

1. Use the touch zones to create your password. Each zone corresponds to a character: 0, 2, 4, C, 6, 8 and X.
  - NB: minimum 6 digits, maximum 14.

2. When you have entered the password, confirm with the crown. You can return to the previous screen at any point by using the BACK push-piece.

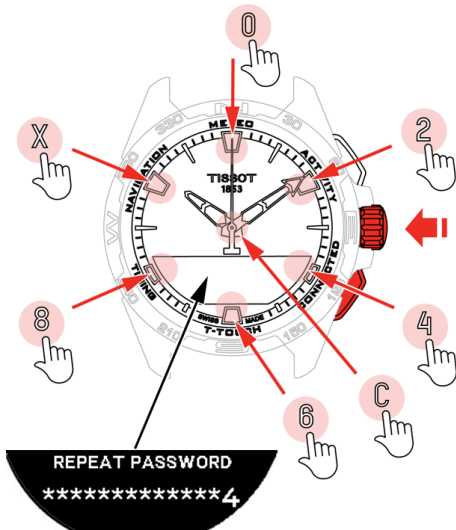

3. Enter the password a second time, then confirm with the crown.

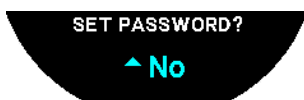

4. To avoid defining a password, select "No" and proceed to the next step.

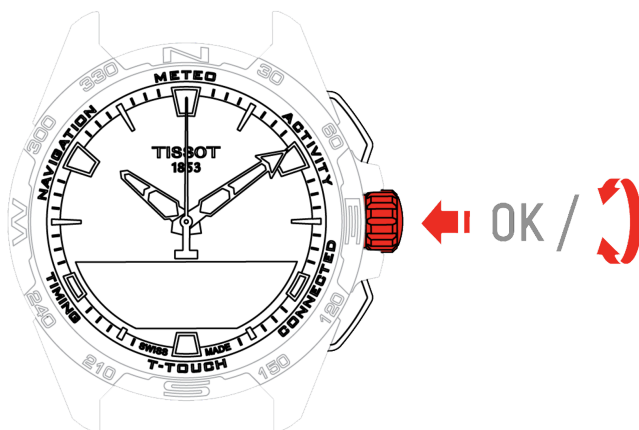

5. Use the crown to adjust the watch settings manually:

**"GENDER"**

- Male, female or undefined.

- Centimetres or Feet;
- Enter your height.

## **"WEIGHT UNIT"**

- Kilograms or Pounds;
- Enter your weight.

## **"DATE FORMAT"**

- DD.MM.YY (day.month.year) or MM.DD.YY (month.day.year).

## **"DATE OF BIRTH"**

- Select the year, month and day.

## **"DATE"**

- Enter today's date.

## **"TIME FORMAT"**

- 24-hour or 12-hour.

## **"TIME 1" (Time)**

- Enter the time.

The message "Setup completed" appears, which means the installation has been successfully completed.

The hands position themselves to the time you entered and the watch automatically self-locks.



## Reconnecting the watch to the phone

When the watch is connected to the phone, this is indicated by the icon 

When the watch is temporarily out of the phone's range, it will try to reconnect for a period of 2 hrs. This is indicated by the "reconnecting" icon. In this situation, you need only bring the watch to within a few metres of the phone in order to reconnect, provided that the phone's bluetooth is active.

After this period, in order to save its battery, the watch will cut the bluetooth signal; no connection icon will be displayed. From version 2.0, you need only press one of the (BACK / START / CROWN) buttons to reactivate the signal. The "reconnecting" icon will be immediately displayed.



## Clock

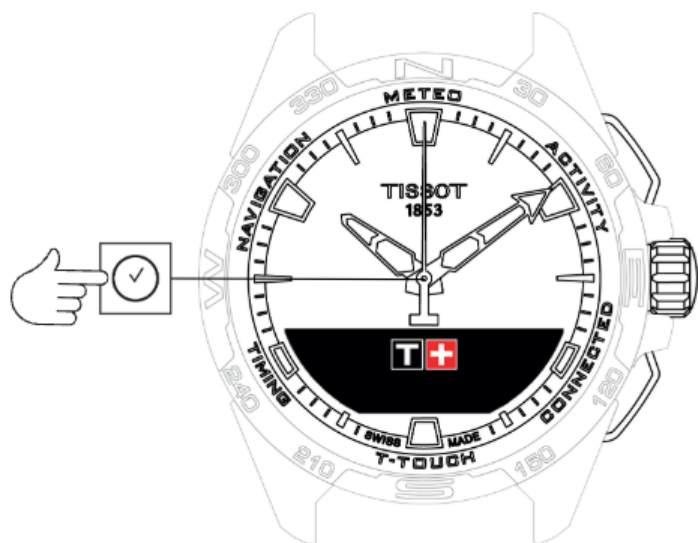

### To access the "Clock" functions:

1. Unlock the watch with a long press on START.
2. Press the "Clock" touch zone.
  - Pressing and turning the crown will give you access to the following functions:



#### ! INFO

Please note: You can go backwards at any time by using the BACK push-piece.

### Additional information

- TIME 1 and TIME 2
- Date



## **TIME 1 and TIME 2**



Set Time



Timezone



Swap with Time 2 (Changing to the second time)



## Set Time

### In unpaired mode

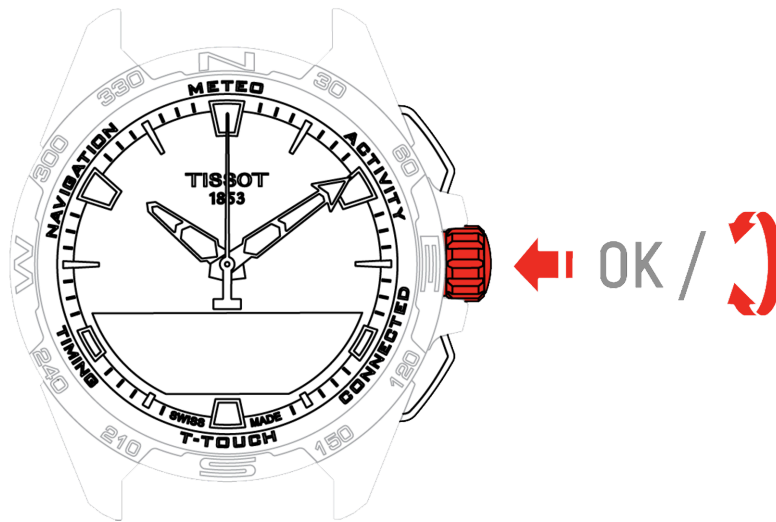

1. Turn the crown to display TIME 1, press the crown, the watch displays "Set time 1"
2. Confirm by pressing the crown
  - Using the crown enter the time then confirm by pressing the crown



## Timezone

### In paired mode

The watch has two times, TIME 1 and TIME 2, for which you can choose the desired time zone from a list that can be modified on the Tissot smartphone app. The hands always display TIME 1.

The list of time zones contains:

- The "phone" time zone, which is the smartphone's time zone.
- The "custom" time zone, which enables you to set the time manually
- The time zones of various cities and other places as listed on the T-Touch Connect Solar smartphone app

#### INFO

Please note: When changing between summer and winter time, the watch will inform you of the change 18 hours beforehand and will update itself automatically.

## Swap with Time 2 (Changing to the second time)

The "Swap" function enables swapping between the times set in TIME 1 and TIME 2.



### ⓘ INFO

Please note that this function is available only when TIME 1 and TIME 2 have been set.



## Date

The T-Touch Connect Solar watch is equipped with a calendar:

-  : in paired mode the date is synchronised automatically with the watch.
-  : in unpaired mode, settings are entered manually:

1. Press the crown
  - "Set Date?"
2. Press the crown
3. Enter today's date



## METEO (Weather)

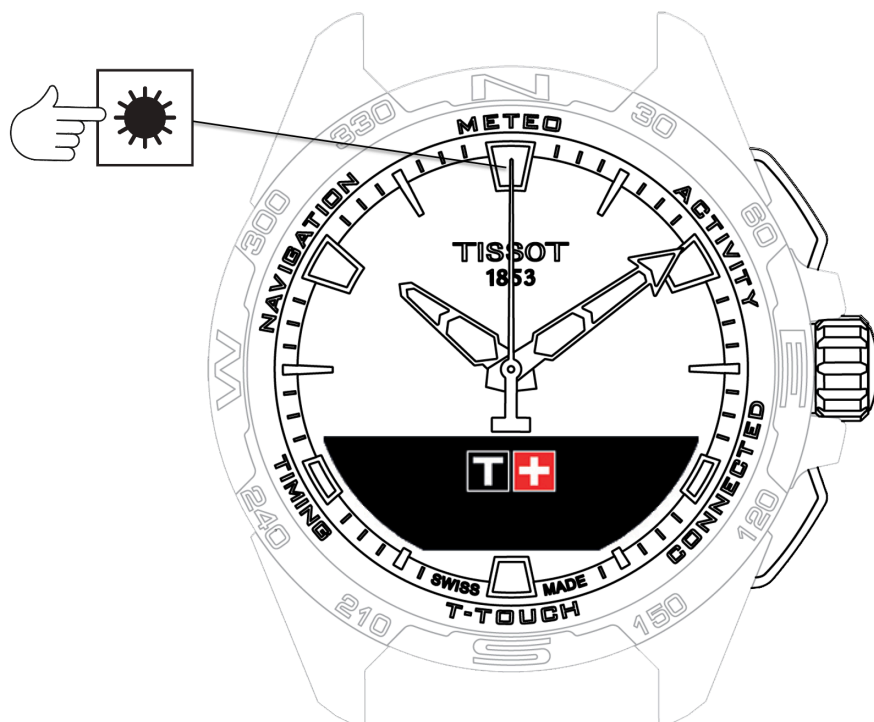

### To access the "METEO" (Weather) functions:

1. Unlock the watch with a long press on START.
2. Press the "METEO" touch zone.
  - Pressing and turning the crown will give you access to the following functions:

-  **BAROMETER**
-  **TEMPERATURE**

#### ! INFO



Please note: You can go backwards at any time by using the BACK push-piece.

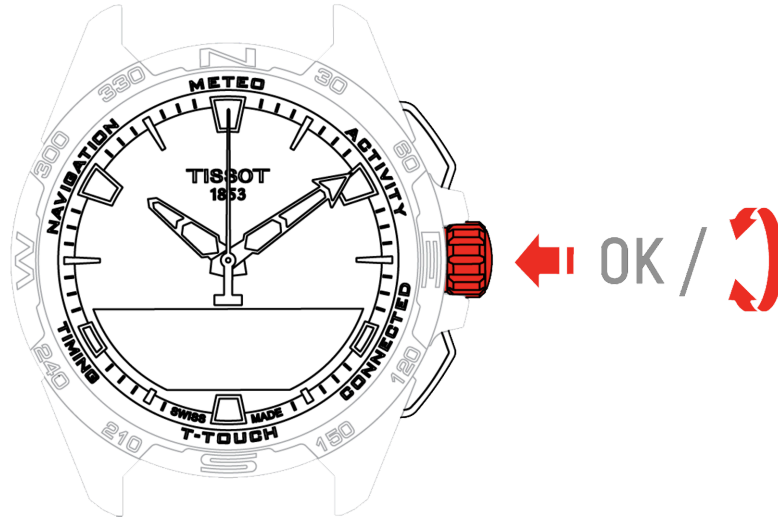

## BAROMETER



Pressing and turning the crown will give you access to the following functions:

-  Calibrate relative pressure
-  Absolute pressure
-  Glossary

## Calibrate relative pressure

Adjusting the relative pressure causes the displayed altitude to change. The relative pressure is intentionally restricted to between 950 hPa and 1,100 hPa.

## Absolute pressure

Absolute atmospheric pressure is the actual pressure at the time and place the measurement is taken, and cannot be modified.

To obtain the most accurate barometer readings, you have the option to adjust the hemisphere and climate zone based on your geographical location. In the "T-TOUCH" / "SETTINGS" / " Calibration" / "Altimeter" functions, select your climate zone either manually or automatically, using the simplified Koeppen climate classification (see illustration below). If the watch is not set ("Not Set"), the standard atmosphere model is used: set temperature at sea level = 15°C, mean pressure at sea level: 1013.25 hPa.

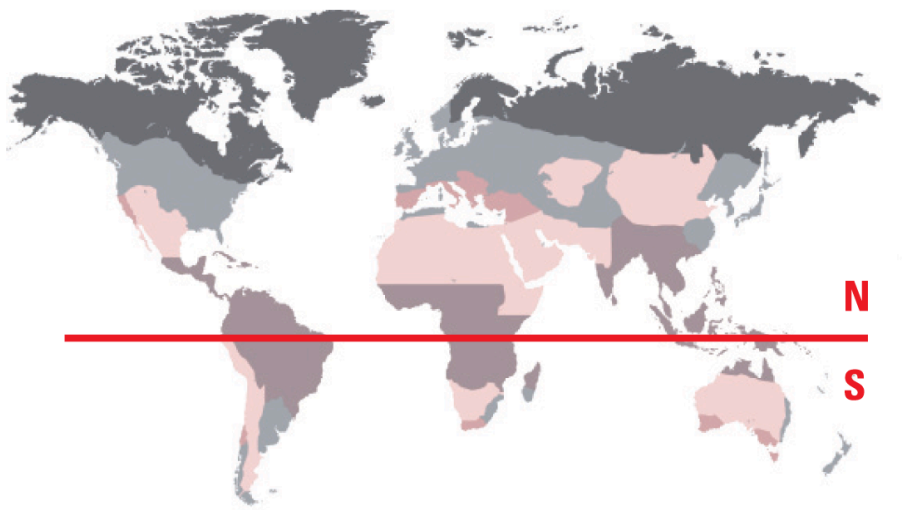

- Polar
- Temperate
- Arid
- Tropical
- Mediterranean



## Glossary

In Meteo mode, the hands are superimposed to indicate the weather trend. The advantage of the barometer is that it enables the relative atmospheric pressure to be displayed. This relative pressure is displayed in hectopascals.

Changes in the weather are related to variations in atmospheric pressure. When the atmospheric pressure rises, the sky clears. The area is then referred to as one of "high pressure", or an "anticyclone". When the atmospheric pressure falls, the sky clouds over. The area is then referred to as one of "low pressure" or a "depression".

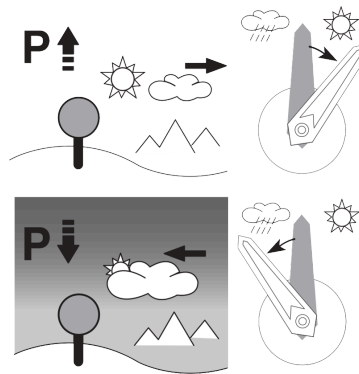
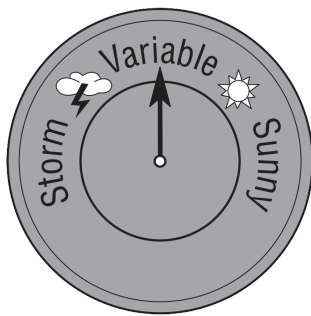

- The T-Touch Connect Solar watch measures these pressure variations and indicates the weather trend with the hands, which can adopt the following 7 positions according to the weather developments:

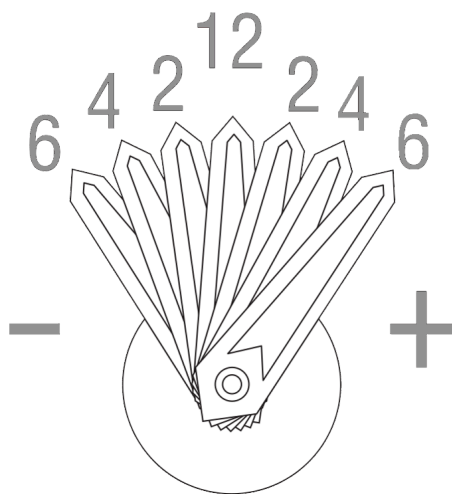

- +6': Sharp fall in pressure, rapid deterioration
- +4': Moderate fall in pressure, deterioration likely
- +2': Slight fall in pressure, slight deterioration likely
- 12h: No appreciable change in the weather
- 2': Slight rise in pressure, slight improvement likely

-4': Moderate rise in pressure, improvement likely

-6': Sharp rise in pressure, rapid improvement

The T-Touch Connect Solar program takes account of atmospheric pressure variation over the last 6 hours to calculate the trend to indicate. In addition, the pressure variation caused by a rapid change in altitude is detected by the watch and compensated for automatically. It therefore has only a minimal influence on the barometric trend. The T-Touch Connect Solar's digital display shows the absolute and relative atmospheric pressure values in hectopascals [hPa]. Absolute atmospheric pressure is the actual pressure at the time and place the measurement is taken, and cannot be modified. Relative pressure is a value relating to sea level, based on the local absolute atmospheric pressure. Barometers and weather maps show relative pressure values. The relative pressure value depends on the climate zone set, and can be preset on the watch. The relative pressure presetting is related to the altitude.

Measurement range:	absolute pressure: 250 hPa to 1200 hPa relative pressure: 950 hPa to 1100 hPa
Precision:	absolute pressure: ± 3 hPa
Relative pressure:	changes with the altimeter
Resolution:	1 hPa
Unit conversion:	1 hectopascal [hPa] = 1 millibar [mb]



## TEMPERATURE

The temperature displayed is the temperature of the watch case. This is, in turn, affected by the body’s temperature. This is why the temperature displayed may differ from the ambient temperature.

In order to display the actual ambient temperature, the watch must be removed from the wrist until no longer affected by the body’s temperature (this takes around 15 to 30 minutes).

The temperature can be displayed in degrees Celsius [°C] or degrees Fahrenheit [°F].

<b>Measurement range:</b>	<b>-10°C to +60°C</b>	<b>14°F to 140°F</b>
Accuracy:	± 1°C	± 1.8°F
Resolution:	1°C	1°F





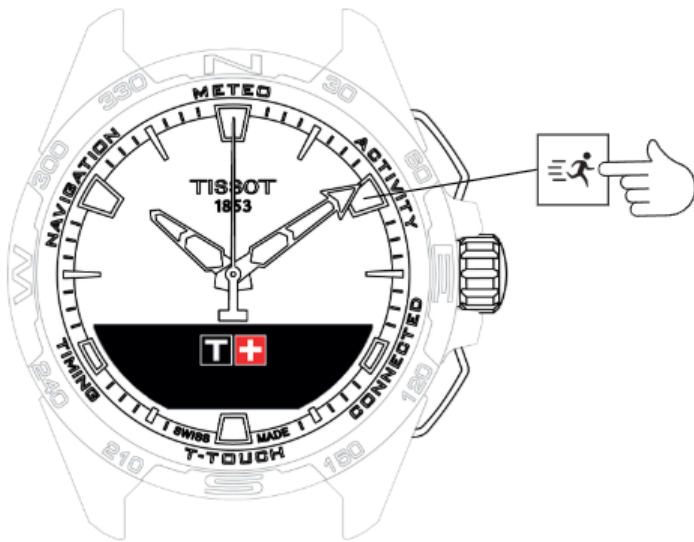

## ACTIVITY



### To access the "ACTIVITY" functions:

1. Unlock the watch with a long press on START.
2. Press the "ACTIVITY" touch zone
  - Turning the crown will give you access to the following functions:

-  **ACTIVITY**
-  **DAILY STEPS**
-  **ALTIMETER**
-  **BRING ME BACK**

### ! INFO

- Please note: You can go backwards at any time by using the BACK push-piece.

- Please note: The "BRING ME BACK" function is only available if the "ACTIVITY" function is operating.



## ACTIVITY

The T-Touch Connect Solar enables you to record an outdoor activity using the "ACTIVITY" function (e.g. when mountain hiking). This function indicates the elapsed time, the number of steps, the number of calories, the current altitude, the cumulative elevation gains and losses, and the average vertical ascent and descent speeds.

### INFO

This function is limited or unavailable in some parts of the world.

In non-paired mode or when unconnected, not all the "ACTIVITY" features will be available and the GPS coordinates will not be recorded during the trip.

### Additional information

- [Start the activity](#)
- [Description of the specific icons on the watch during the activity](#)
- [Description of the specific watch screens during the activity](#)
- [Stop the activity](#)
- [Activity history](#)
- [T-Touch app specific screens](#)
- [Technical information](#)

## Start the activity

- The watch must be paired to the user's phone in order to be able to make full use of all the app's functions. In addition, it is recommended to be logged into the data network, or have recently logged in.



1. At the trip start point, select "ACTIVITY" by briefly pressing the crown.



2. Start "ACTIVITY" by briefly pressing the crown.
3. If the T-Touch app is in the background or closed, the watch screen will display the message instructing the user to open it to activate it.

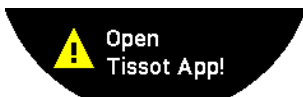

- The T-Touch app must have the necessary permissions to use the phone's GPS function.

When the "ACTIVITY" is saved, you can pause the function at any time by briefly pressing the "START" push-piece.

## Description of the specific icons on the watch during the activity



Activity tracking in progress;



Activity tracking in progress;



Activity tracking in progress;

The phone's GPS signals are active.

These two similar icons distinguish whether the GPS signal is active or lost. If the GPS signal is lost, the activity tracker cannot save the coordinates.

If the GPS signal is lost, it is recommended to stop and wait a few minutes for the signal to return. But according to the location (e.g.: in an enclosed valley or near steep slopes), there is no point waiting for this signal to return; in this case it is preferable to continue on the route.

**! INFO**

Note: These icons are only visible in the top left of the watch screen when it is locked.

## Description of the specific watch screens during the activity

During the trip, the "ACTIVITY" function displays the elapsed time, number of steps, total distance, number of calories, current altitude, cumulative elevation gains and losses, average vertical ascent and descent speeds, and access to the "BRING ME BACK" function.

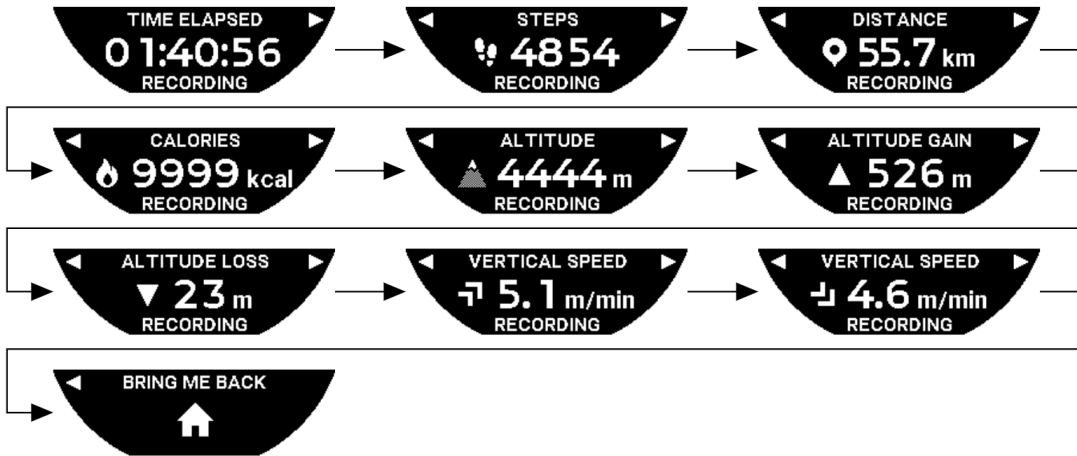

## Stop the activity

At the trip end point:

1. Stop the "ACTIVITY" function on the watch screen by briefly pressing the BACK push-piece.



2. Confirm the message by pressing on the watch screen, or press the crown.

## Activity history

In the "ACTIVITY" function, press and turn the crown to look up your history:



## T-Touch app specific screens

The T-Touch app displays the trip history. The recorded GPS points (via the phone location function) are used to display the plot on a geographic map. The accuracy of the points is directly related to the quality of the phone's GPS reception. A summary table also displays the following data: start date and time, end date and time, elapsed time, number of steps, total distance, number of calories, starting altitude, cumulative altitude gains and losses, average vertical ascent and descent speeds.

## Technical information

If the watch and phone are in paired mode, the "ACTIVITY" function saves all the data during the trip. As soon as the trip has finished, this data can be viewed on the watch screens, and they are also formatted in the app installed on the phone, for improved user-friendliness.

### ⓘ INFO

This function is limited or unavailable in some parts of the world.



## BRING ME BACK

The T-Touch Connect Solar guides you back to the start point of a trip being saved, either in a straight line or following the waypoints on the recorded track (in reverse order). This function displays the distance remaining on-screen, and the watch hands indicate the direction (azimuth) to follow.

### DANGER

#### Risk of falling

The watch indicates the activity's start point as a straight line from the current position. This azimuth should be interpreted with care in relation to the location's topography. This is to avoid slips or falls (cliff, crevasse, body of water, impassable obstacle or other natural hazard).

### INFO

Note: The "BRING ME BACK" function is only available if the "ACTIVITY" function is operating.

## Additional information

- [Start the Bring Me Back function](#)
- [Changing mode for the "Bring Me Back" function](#)
- [Optimising the "Bring Me Back" route](#)
- [Description of the specific watch screens on the way back](#)
- [Description of the specific watch icons on the way back](#)
- [Automatic function stop](#)
- [Technical information](#)

## Start the Bring Me Back function

If you want to interrupt your trip, and want to return to the start point guided by the T-Touch Connect Solar, you must start the "BRING ME BACK" function on the watch screen using the crown.

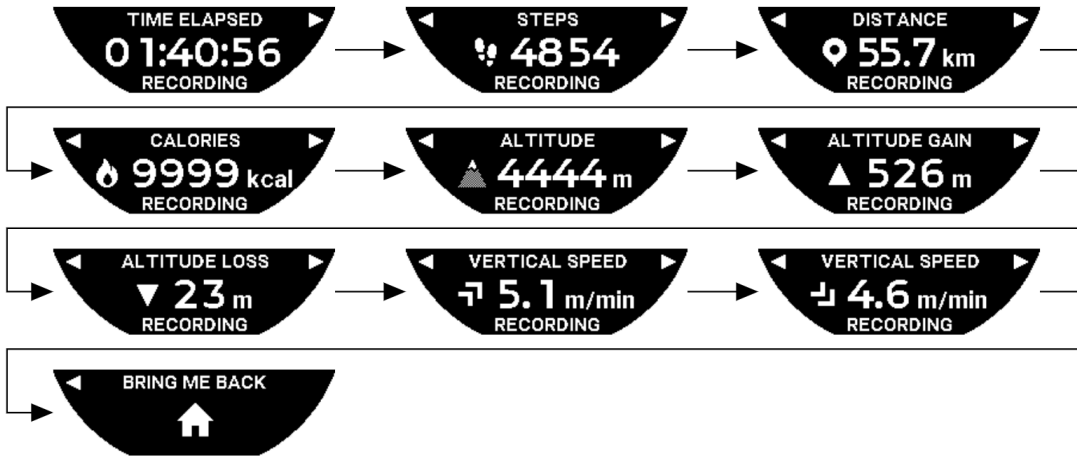

### ! INFO

Note: The "BRING ME BACK" function is usable as soon as a GPS point has been saved. If this is not the case, the function is not available, and the following screen will be displayed:



## Changing mode for the "Bring Me Back" function

There are two modes to choose from for the "Bring Me Back" function: direct or waypoints. Direct (or linear) mode guides you back to the start point of a trip being saved, in a straight line. Waypoints mode guides you back following the waypoints on the recorded track (in reverse order).

If the "BRING ME BACK" function is in operation, you can change the mode by briefly pressing the crown.

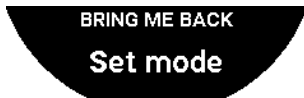

## Optimising the "Bring Me Back" route

You can opt to optimise the "Bring Me Back" route at any time, to follow the shortest path.

If the "BRING ME BACK" function is in operation, you can optimise the route by pressing and turning the crown.



## Description of the specific watch screens on the way back

In direct mode, the distance remaining to the start point is displayed on the watch screen.



If the watch is locked, the following screen will be displayed:



In waypoints mode, the distance remaining to the next waypoint and the distance remaining to the start point are displayed on the watch screen.



If the watch is locked, the following screen will be displayed:



On the way back to the start point, the watch uses the GPS signal to guide you. These data are permanently calculated, and depend on the GPS signal received. Depending on the environment you are in, the signal may be lost for a brief moment. In this case, the watch screen displays a flashing satellite icon, to indicate that "GPS" reception is insufficient to guide you precisely.



If the watch is locked, the following screen will be displayed:



If the GPS signal is lost, it is recommended to stop and wait a few minutes for the signal to return. But according to the location (e.g.: in an enclosed valley or near steep slopes), there is no point waiting for this signal to return; in this case it is preferable to continue on the route.

## Description of the specific watch icons on the way back



Activity tracking in progress;



GPS signals insufficient;



GPS signals active.

These two similar icons distinguish whether the GPS signal is active or lost.

If the GPS signal is lost, it is recommended to stop and wait a few minutes for the signal to return. But according to the location (e.g.: in an enclosed valley or near steep slopes), there is no point waiting for this signal to return; in this case it is preferable to continue on the route.

**!** **INFO**

Note: These icons are visible only in the top left of the watch screen when it is locked.

## Automatic function stop

When you are approaching +/- 50 m from your start point, the "BRING ME BACK" function finishes, and the following message will be displayed on the watch screen:



If the watch is locked, the following screen will be displayed:



**ⓘ INFO**

Note: Please note that before returning the start point, if you stop the "ACTIVITY" function prematurely, the "BRING ME BACK" function will also be interrupted.

## Technical information

This function uses a lot of the battery resources of the phone and the watch. If the phone no longer has enough battery, the watch will continue to guide you. However, in this extreme emergency situation, the minimum remaining life with just the watch battery cannot be indicated.

GPS signal detection is sensitive to electromagnetic disturbances and geographic location. It is really necessary to hold the watch flat, facing upward and a long way from metal surfaces to obtain the best possible GPS signal reception.



## DAILY STEPS

In activity tracker mode, the T-Touch Connect Solar measures daily physical activity by counting the number of steps taken.

These daily data are always calculated by reference to TIME 1, and changing TIME 1 automatically causes the daily data to be refreshed.

For more detailed activity tracking, more data are estimated, such as distance covered, number of calories burned and duration of activity.

Pressing and turning the crown will give you access to the following data:



CALORIES



DISTANCE



ACTIVITY PERIOD



STEPS GOAL



## CALORIES

Displays the number of calories burned during the day.



## DISTANCE

Displays the distance covered during the day, in kilometres (km) or miles (mi). This is calculated based on the daily number of steps.



## **ACTIVITY PERIOD**

Displays the duration of the day's activity.



## STEPS GOAL

The default daily steps goal is 5000. This figure can be altered by using the crown.

When the day's goal has been reached, a "goal alert" notification is displayed, accompanied by a beep or a vibration. This notification can be personalised in the watch Profile.

-  : in paired mode

The "STEPS GOAL" can also be set in the app. In addition, daily activity records for up to 10 years can be consulted in the app.



## ALTIMETER

The watch automatically calibrates the altitude twice per day. The manual function is still available for more precise operation.



[ALTITUDE SETTING \(Altitude calibration\)](#)



[Glossary](#)



## ALTITUDE SETTING (Altitude calibration)

"Calibrating" an altimeter means setting it to the known altitude at a particular point. You can reset the altitude by using the crown. Actual altitude values are displayed in various places: on signposts, and on contour lines and spot elevations on maps. Altitude must be "calibrated" in relation to the ambient atmospheric pressure.

<b>Measurement range:</b>	<b>- 400 m to +9000 m</b>	<b>- 1312 ft to +29,527 ft</b>
Resolution:	1 m	3 ft

### ⓘ INFO

Note: The average pressure at sea level is 1013.25 hPa.

To obtain the most accurate altimeter function, you can adjust the hemisphere and climate zone based on your geographical location. In the "T-TOUCH" / "SETTINGS" / " Calibration" / "Altimeter" functions, select your climate zone either manually or automatically, using the simplified Koeppen climate classification (see illustration below). If the watch is not set ("Not Set"), the standard atmosphere model is used: set temperature at sea level = 15°C, mean pressure at sea level: 1013.25 hPa.

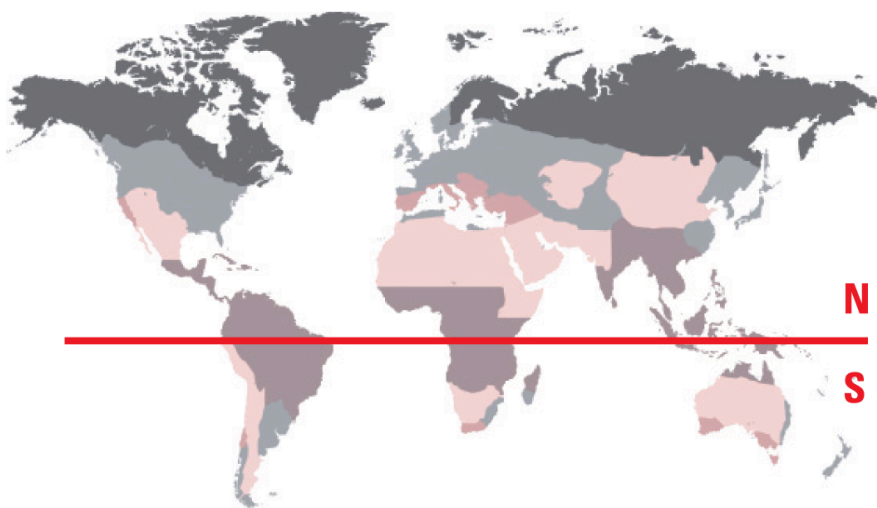

 Polar

 Temperate

 Arid

 Tropical

 Mediterranean



## Glossary

In altimeter mode, the T-Touch Connect Solar becomes a barometric altimeter and displays the altitude in relation to the average sea level. The measurement unit used to display the altitude (m or ft) is the unit that was selected in the options.

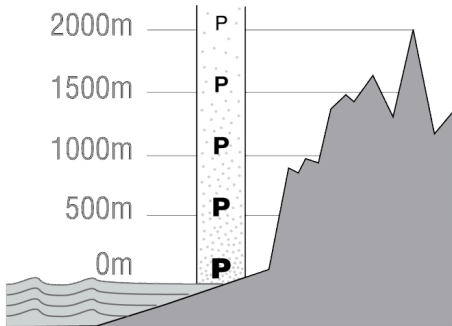

Note: Because pressure is used to calculate altitude, the altimeter is sensitive to variations in atmospheric pressure as the weather changes. It is not unusual to observe differences in altitude of 100 m in a single night. The value displayed can thus vary even though the altitude has not actually changed.

Change in the weather = pressure variation = change in the altitude displayed

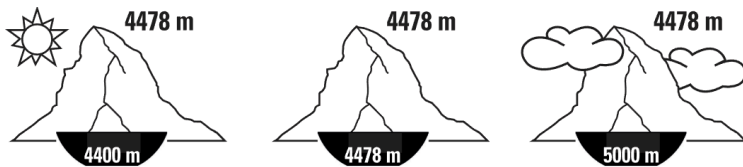





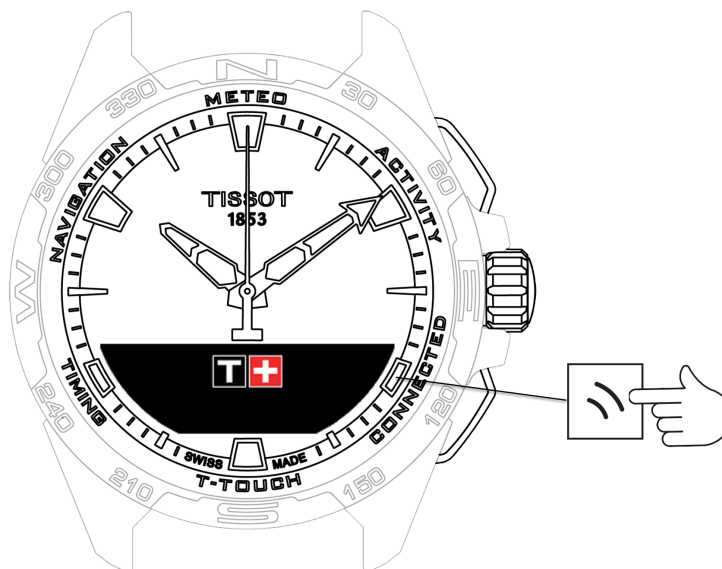

## CONNECTED



### To access the "CONNECTED" functions:

1. Unlock the watch with a long press on START.
2. Press the "CONNECTED" touch zone.

Pressing and turning the crown will give you access to the following functions:

-  Incoming call
-  NOTIFICATONS (message, e-mail, reminder, social media)
-  FIND MY PHONE
-  Find my watch
-  NBA

Please note: You can go backwards at any time by using the BACK push-piece.



## Incoming call

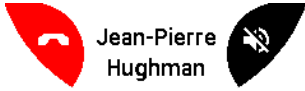

On receipt of an incoming call, you can:

- Put the watch in silent mode by pressing "mute" symbol on the right of the MIP screen or pressing the crown
- Reject the call by pressing "hang up" symbol on the left of the MIP screen or pressing BACK



## NOTIFICATONS (message, e-mail, reminder, social media)

When the watch is paired with and connected to a smartphone, it can display notifications sent by the smartphone (message, e-mail, call, social media). The choice of notifications to be sent from the smartphone to the watch is made in the smartphone settings and depends on the smartphone's operating system.

On receipt of a notification, you can:

- Open the notification by pressing and turning the crown to scroll through the notification. At the end, the message "CLEAR?" is displayed, and pressing the crown deletes the notification from the watch.
- To hide the notification, click on the BACK push-piece, and the notification will be stored in "NOTIFICATIONS".
- If you do nothing, the notification remains visible on the MIP screen for 15 seconds, after which time it is automatically stored in "NOTIFICATIONS".

To read or delete hidden and non-deleted notifications:

- When "NOTIFICATIONS" is displayed, confirm by pressing the crown, and turn the crown to browse through the various notifications received.
- Open a notification by pressing the crown, and turn the crown to scroll through the notification. At the end, the message "CLEAR" is displayed, and pressing the crown deletes the notification from the watch.



## FIND MY PHONE

If the watch is paired with and connected to a smartphone, it can make the phone ring in order to help find it if it is hidden.

The "Start" screen will be displayed; activate the ringtone by pressing the crown. If this located the phone, stop the ringtone by pressing the crown again.

### ! INFO

Note: if the phone uses an iOS system, the ringtone volume depends on the setting on the phone. You cannot make the phone ring if it is in silent mode.



## Find my watch

If the watch is paired with and connected to a smartphone, it is possible to make the watch chime from the T-Touch Connect Solar app, in order to find it.



## NBA

In NBA mode, the watch displays the result of your favourite team's latest match, as well as the date of its next fixture.

- Press and turn the crown to display your favourite team's calendar.

### ⓘ INFO

Please note: Sign into the app to choose your favourite team, as well as to access more information on the NBA season.



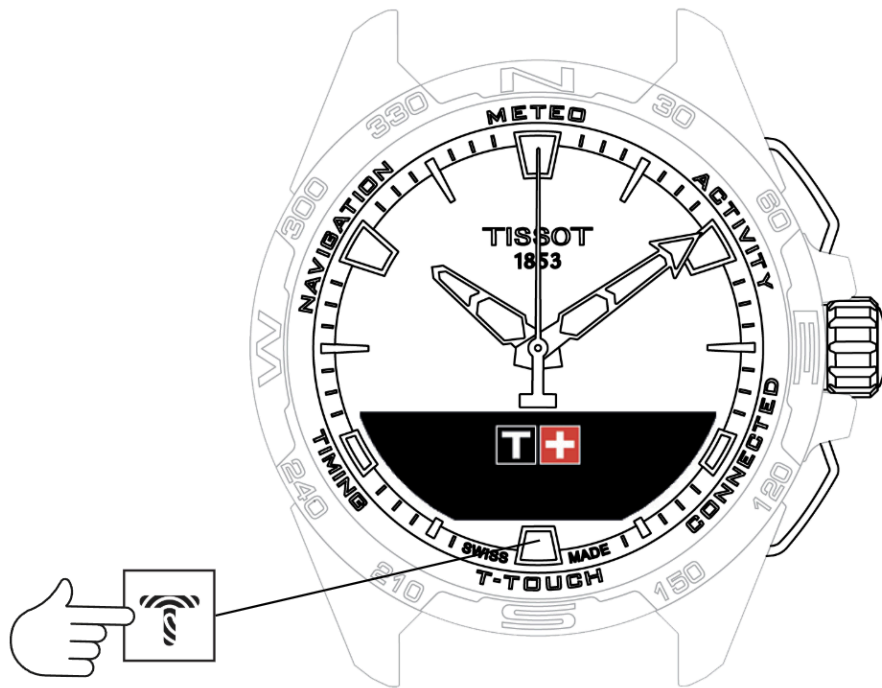

# T-TOUCH



## To access the "T-TOUCH" functions:

1. Unlock the watch with a long press on START.
2. Press the "T-TOUCH" touch zone.

Pressing and turning the crown will give you access to the following functions:

-  QUICK SETTINGS
-  WATCH SETTINGS

### ! INFO





Please note: You can go backwards at any time by using the BACK push-piece.



## QUICK SETTINGS

Use quick settings to check some of the watch's settings quickly.

1. Press the crown to activate or deactivate the following quick settings:

-  "Bluetooth" (Quick setting of Bluetooth®)
-  "Sound" (Quick setting of sound)
-  "Vibration" (Quick setting of vibration)
-  "BATTERY LEVEL"
-  "SOLAR ENERGY"



## "Bluetooth" (Quick setting of Bluetooth®)



Activation or deactivation of Bluetooth®.

### ! INFO

Please note: The T-Touch Connect Solar is disconnected from the smartphone.



## "Sound" (Quick setting of sound)



The watch's sound alerts are activated or deactivated.

### **!** INFO

Please note: Alarm and timer sounds remain active regardless of this setting.



## "Vibration" (Quick setting of vibration)



The watch's vibration alerts are activated or deactivated.

### ! INFO

Please note: Alarm and timer vibrations remain active regardless of this setting.

-  : in paired mode

When the watch is paired with a smartphone, you can control the watch's Bluetooth® technology using additional quick settings.



## "BATTERY LEVEL"



Indicates the current battery level.

### ⓘ INFO

Note: The battery level is represented by coloured bars. When the watch is fully charged, the battery level is represented by 8 green bars. When the battery is nearly drained, its level is represented by a red bar.



## "SOLAR ENERGY"

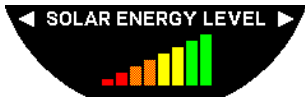







Indicates the current solar energy level received by the watch.

### ⓘ INFO

Please note: The energy level is represented by coloured bars. The full scale corresponds to exposure to sunlight.



## WATCH SETTINGS

-  "Pair with phone"
-  "CONNECTION" (Connection settings)
-  System
-  User profile
-  Calibration
-  About
-  E-labelling



## "Pair with phone"



: available only in unpaired mode

When the watch is operating in unpaired mode, you have the option to pair it with your phone at any time.

### **INFO**

Please note that data stored in the watch will be deleted if you confirm this option.

Please note: It is necessary for the latest version of the Tissot T-Connect app to be installed on your phone.



## "CONNECTION" (Connection settings)

In this sub-menu, you can adjust the settings for connecting the watch to the phone.

### "Alerts" (Connection alerts)



Activation or deactivation of communication alerts.

#### ! INFO

Please note: If this setting is active, the watch will notify you each time it connects to or disconnects from the phone.

### "Notification"



Activation or deactivation of receipt of notifications from the phone.

#### ! INFO

Please note: If this setting is active, the watch will receive notifications from the phone.

### "Unpair from phone" (Disconnect the watch from the phone)

This action disconnects the watch from your phone and does not allow synchronisation of your data in the Tissot T-Connect app.



## System

In the "System" sub-menu, you can adjust the watch's system options.

### "Language"

In the "Language" sub-menu, you can set your watch's language. Please refer to the "compatibility" chapter to find out which languages your watch supports.

### "Time (date and time)"

In the "Time" (Date and time) sub-menu, you can adjust all the watch's date and time settings, such as the date and time display format, and the first day of the week.

### "Code"

In the "Password" sub-menu, you can manage the watch's password. When the password is activated, the watch automatically locks itself when disconnected from the phone or if you press simultaneously on the "START" and "BACK" push-pieces.

### "Sounds"

In the "Sounds" sub-menu, you can set the acoustic and vibration signals for notifications and for browsing through the watch's menus.

#### INFO

Please note: Alarm and time sounds and vibrations are always active regardless of this parameter.

### "Units"

In the "Units" sub-menu, you can adjust all the watch's units.

### "Energy saving"

The "Energy saving" sub-menu enables you to manage your watch's consumption.

## Activation and deactivation of "Auto sleep" mode

### ⓘ INFO

Please note: When this mode is activated, the watch automatically enters sleep mode when it has not been worn for at least 2 hours. When the watch is in sleep mode, the hands are stopped and the screen, backlighting and Bluetooth® are turned off to save energy.

You can enter this mode manually by selecting "Enter sleep mode."



## Activation and deactivation of "Eco mode"

This mode increases battery life by reducing the watch's performance. For example, the connection with your phone is slower and vibration and backlighting are deactivated.

Below you will find the complete list of functions which are downgraded to extend battery life:

- The vibration is deactivated
- The buzzer is deactivated, except for alarms and the timer
- Automatic backlighting is deactivated, though manual backlighting is still available
- The altimeter refreshes its altitude every 5 seconds
- The Chrono displays "IN PROGRESS" instead of the current time

## "Restore to factory settings"

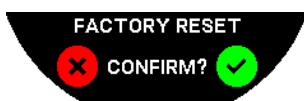

You can restore the watch to its factory settings from this sub-menu.

**ⓘ INFO**

Please note: If you opt to restore the factory settings, all data not yet synchronised with the Tissot T-Connect mobile app will be lost. The connection with your phone will be deleted and you will have to remove your watch from your phone's connection settings if you wish to initiate the connection procedure again.



## User profile

In the "User profile" sub-menu, you can change all your user profile details as well as the alert reception settings.

### "Move alerts"



Activation and deactivation of reception of alerts when you are not moving enough.

#### ! INFO

Please note: If you have not been moving enough for a period of time, the watch issues an alert prompting you to move.

### "Goal alerts"



Switch alerts on/off notifying you when you reach the goal you have set for a daily number of steps.



## Calibration

In the "Calibration" sub-menu, you can calibrate and adjust all the watch's sensors and motors.

### "Compass"

To maximise compass accuracy, you can adjust the correct magnetic declination value (for place and date), either automatically or manually. You can also calibrate the compass as explained in the "NAVIGATION/Compass" chapter.

### "Barometer"

To obtain the most accurate barometer readings, you have the option to adjust the hemisphere and climatic zone based on your geographical location.

### "Altimeter"

To obtain the most accurate altimeter readings, you can adjust the hemisphere and climatic zone based on your geographical location.

### "Motors"

When the watch hands are no longer showing the correct time, you can calibrate the motors automatically from this sub-menu. This synchronisation takes place automatically every night.



## About

In the "About" sub-menu, you can obtain full details about the watch.



## E-labelling

In the "About" menu, you will find all the information on e-labelling



## TIMING (Timing and Alarm)

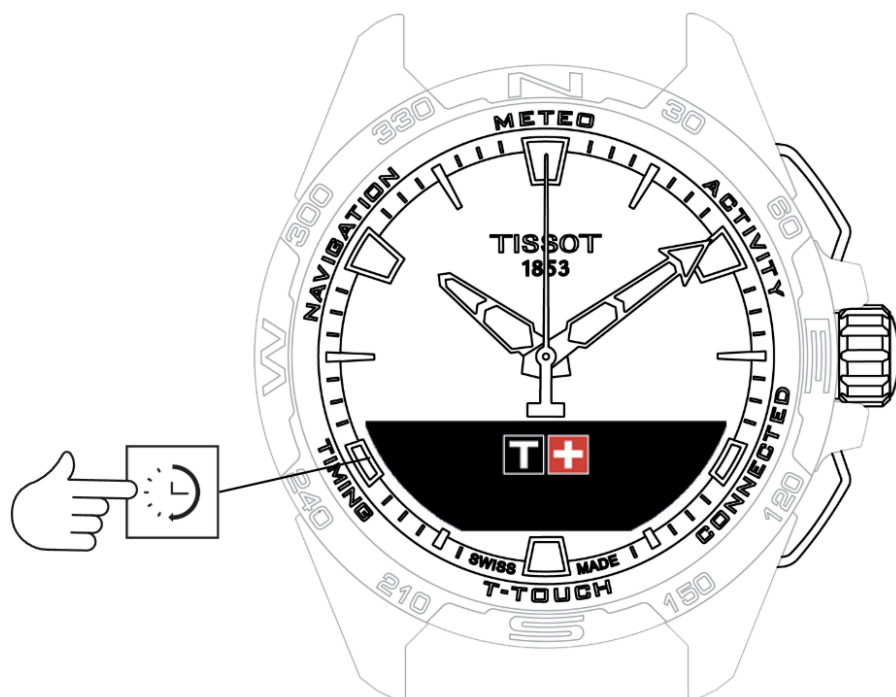

### To access the "TIMING" (Timing and Alarm) functions:

1. Unlock the watch with a long press on START.
2. Press the "TIMING" touch zone.

Pressing and turning the crown will give you access to the following functions:

- CHRONO (Timing)
- TIMER
- ALARM

Please note: You can go backwards at any time by using the BACK push-piece.



## CHRONO (Timing)



In "CHRONO" mode, various types of timing are available in addition to basic timing, such as lap timing and intermediate timing.

Activation of timing functions:

1. Give the "START" push-piece a short press to start the timer
2. Give the "BACK" push-piece a short press to enter an intermediate time (e.g. lap time or arrival of first runner)
3. Give the "START" push-piece a short press to stop the timer (e.g. end of last lap or arrival of last runner)
4. Give the "START" push-piece a short press to reset the timer to zero

To choose between Lap Timing and Intermediate Timing:

- Select "Set mode" by pressing and turning the crown. You will now have access to "Set mode", enabling you to choose between timing types, and "LOGBOOK", for the most recent times recorded.

-  LAP (Lap timing)
-  SPLIT (Intermediate timing)
-  LOGBOOK



## LAP (Lap timing)

The Lap Timing function is a timer for measuring lap time for a single runner, vehicle, etc. Maximum measurement limit: 99 days 23 hours 59 mins 59 secs.



## **SPLIT (Intermediate timing)**

The Intermediate Timing function is a timer for measuring the total duration of a race for up to 99 runners or vehicles participating in the same timed event. For example: measuring the arrival time of several runners in a 100-metre race.







## LOGBOOK

Regardless of the type of pairing, the "LOGBOOK" function gives you access to the last timing taken, as well as some statistics specific to the type of timing. To access these details, press and turn the crown.

### ! INFO

Please note: The stored data is deleted when you start a new timing from zero.

- Reading stored lap time data:
  -  : in unpaired mode, all times measured by the lap timing function are stored and can be displayed on the watch in the "LOGBOOK" function, together with statistics of the total race duration and the fastest, slowest and average lap times.
  -  : in paired mode, you will also find the most recent times recorded on the T-Touch Connect Solar app. Under the History heading, you will also have access to the most recent timings taken.
  
- Reading stored intermediate time data:
  -  : in unpaired mode, all timings measured by the intermediate timing function are stored and can be displayed on the watch in "LOGBOOK" function.
  -  : in paired mode and with the timer reset to zero, you can see the latest timings recorded on the T-Touch Connect Solar app. Under the History heading, you will also have access to the most recent timings taken.



## TIMER



The "TIMER" function enables you to start a countdown of up to 23 hours 59 mins 59 secs.

1. To adjust the countdown duration, press and turn the crown
2. Give the "START" push-piece a short press to confirm
  - An acoustic signal will sound at the end of the countdown
3. Stop the audible signal by pressing the "X" symbol on the left of the MIP screen, or press BACK
4. Restart the timer by pressing the "reload" symbol on the right of the MIP screen, or press
  -  : in paired mode, the countdown settings can be adjusted and countdown initiated from the T-Touch Connect Solar app.



## ALARM

The T-Touch Connect Solar watch has an Alarm function. An alarm can recur at various intervals. You can programme 30 different alarms.

-  [Setting an alarm](#)
-  [Change, activate or deactivate an alarm](#)



## Setting an alarm

- : in unpaired mode, the setting is made from the watch only:

1. Press the crown
  - "ADD ALARM"
2. Press the crown
3. Use the crown to enter the alarm time, then confirm
4. Use the crown to specify the recurrence:

ONCE:	the alarm will sound once only
WEEKDAY:	the alarm will sound every weekday (Monday to Friday)
EVERY DAY:	the alarm will sound every day (Monday to Sunday)
PERSONALIZED:	the alarm will sound on the days of the week selected by the user, by pressing and turning the crown to select the required day(s)

- : in paired mode, alarms can also be set and adjusted directly from the T-Touch Connect Solar app.



When the alarm sounds you can either turn it off or set it to snooze, in which case the alarm will be repeated 5 minutes later. Please note: a maximum of 3 snoozes is possible.



1. To stop the alarm: press "X" or press BACK
2. To snooze the alarm: press "ZZ" or press START



## Change, activate or deactivate an alarm

-  : in unpaired mode, the setting is made from the watch only:
  1. Press the crown
  2. Use the crown to select the alarm to be changed
  3. Using the crown gives you three options:
    - "Enable"/"Disable"? : To activate or deactivate the alarm
    - "Modify?" : To change the alarm
    - "Delete?" : To delete one alarm or all of them
-  : in paired mode, alarms can also be changed directly from the T-Touch Connect Solar app.



## NAVIGATION

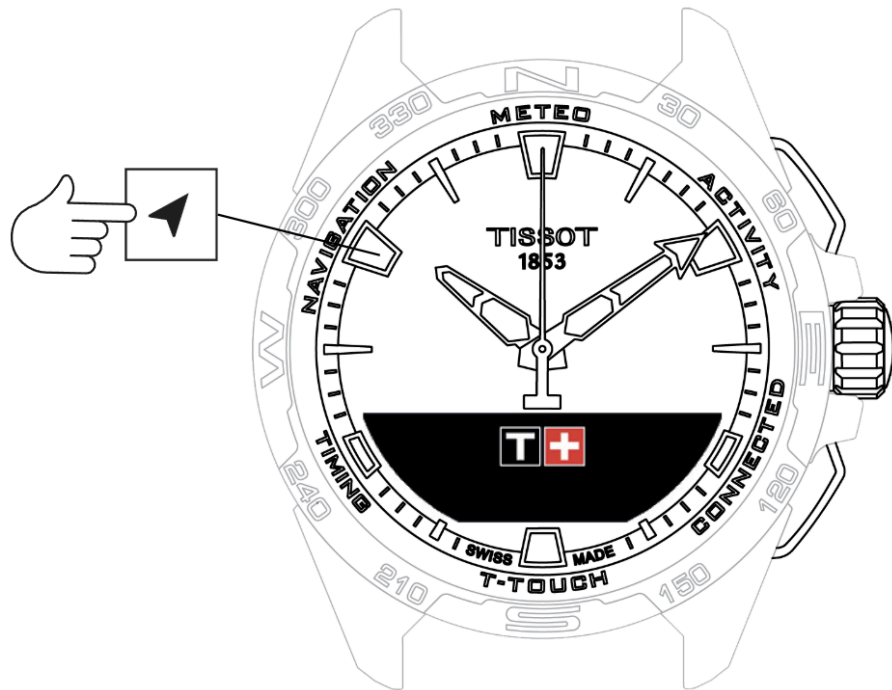

### To access the "NAVIGATION" functions:

1. Unlock the watch with a long press on START.
2. Press the "NAVIGATION" touch zone
  - Press the crown to access the compass function with the chosen display mode.

By default, the compass will indicate magnetic north. Other display modes are available, such as indication of geographic north or azimuthal direction.

- Pressing the crown a second time while turning it will give you access to the following functions:

-  Set mode
-  Azimuth

-  Calibrate
  
-  Glossary

**ⓘ INFO**

Please note: You can go backwards at any time by using the BACK push-piece.



## Set mode

Three types of indication are available: "Magn. North" (magnetic north), "True north" (geographic north) and "Azimuth" (azimuthal direction).

- Select the desired indication by pressing and turning the crown.

### INFO

Note: In "Azimuth" mode, the T-Touch Connect Solar indicates the azimuthal direction (course) you need to follow.



# Azimuth

## "Set azimuth"

The azimuth is the horizontal angle between the direction of an object (course) and geographic north. The azimuth is measured from the north in degrees, from 0° to 359°, and can be adjusted by pressing and turning the crown. When using the compass in azimuth mode, red arrows on the MIP screen show you the direction in which to turn the watch so that the second hand points in the programmed azimuthal direction (course).

In azimuth mode, the T-Touch Connect Solar emits an acoustic signal and displays a visual signal ("Go") when the watch's 6 o'clock-12 o'clock axis is aligned with the azimuthal direction set. The direction of the minute hand represents the azimuth direction in relation to geographic north, while the direction of the hour hand represents geographic north.

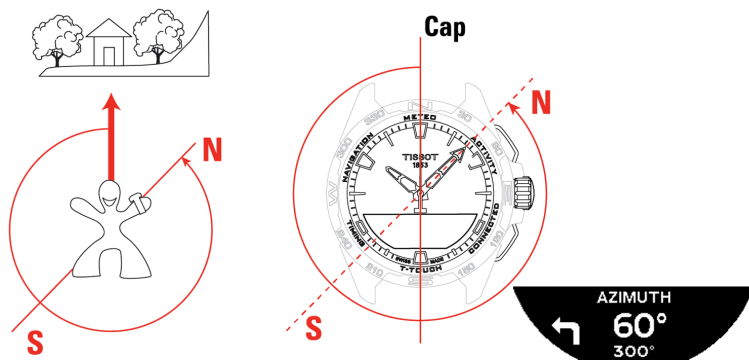



## Calibrate

Various factors affect compass function's precision, and therefore it may be necessary to recalibrate the compass.

1. For accurate calibration, ensure that you are outdoors and well away from any metallic or magnetic body.
2. You now have 60 seconds in which to move your wrist fairly rapidly in a figure-of-eight until you hear a little beep or see "Calibrated" displayed on the MIP screen, indicating that calibration is complete.
3. If "Calibration is unsuccessful" appears on the MIP screen, the calibration operation has failed and you need to restart it.

### ⓘ INFO

Note: For accurate calibration, the watch should not be kept horizontal during the figure-of-eight movements, and it is not necessary to execute a perfect figure-of-eight, the most important thing being for the watch to move within its environment.



## Glossary

In Compass mode the watch indicates magnetic north. Other display modes are available, such as indication of geographic north or azimuthal direction.

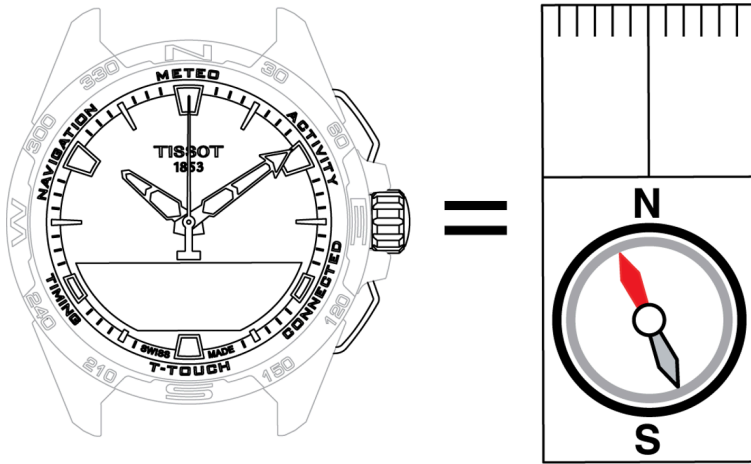

On a geographical map of the world, the vertical lines (meridians) converge towards the Geographic North Pole (gN), thus indicating its direction. The needle on a standard compass, which is often red, points towards the North Magnetic Pole (mN). The angle ( $\alpha$ ) between these two directions, gN and mN, is called the magnetic declination. The value of the magnetic declination thus depends on where you are on the globe.

In addition, the North Magnetic Pole is constantly shifting. The magnetic declination value thus also depends on the date. When the correct (for location and date) magnetic declination value is set, either automatically or manually (see setting procedure under the "T-Touch" heading), the T-Touch Connect Solar's minute hand points towards geographic north (gN). When magnetic declination is reset to zero, the watch points to magnetic north (mN).

Magnetic declination values and dates are shown on topographical maps or can be looked up in dedicated software packages available online.

For the whole world: [www.ngdc.noaa.gov/geomag/calculators/magcalc.shtml](http://www.ngdc.noaa.gov/geomag/calculators/magcalc.shtml)

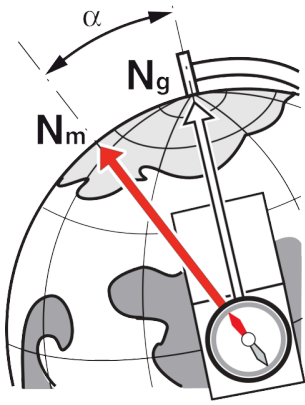

Accuracy:  $\pm 8^\circ$

Resolution:  $1^\circ$

**Note 1:**





For the most accurate indication of North, hold the watch as nearly horizontal as possible.

**Note 2:**

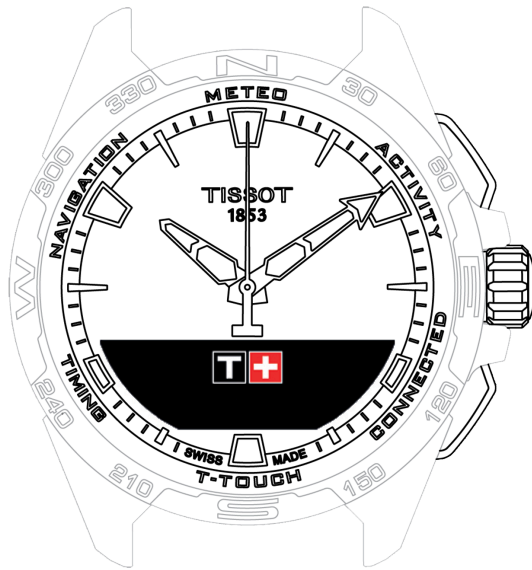
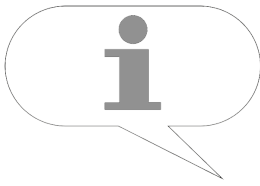
The compass function, like any other compass, should not be used near any metallic or magnetic body, and should preferably be used outdoors. If in doubt, you can recalibrate the compass.

# GENERAL INFORMATION



-  **Basic operations**
-  **Reset the password with a smartphone**
-  **Resetting the password from the watch**
-  **Compatibility**
-  **Versions and new features**



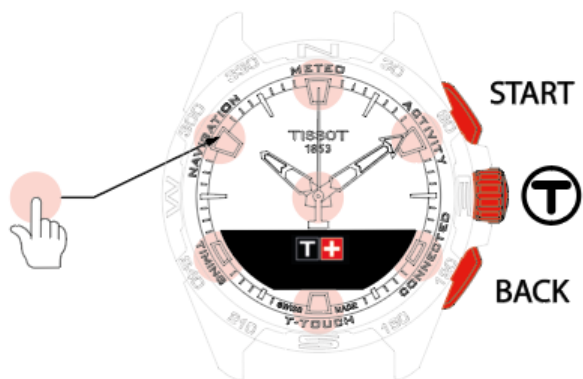

## Basic operations

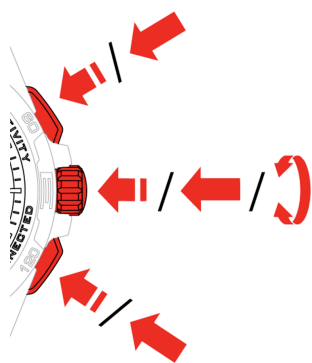

 : Touch zones

 : MIP screen



 : Long press (more than 1/2 a second)

 : Rotation (applies only to the crown)

 : Short press (less than 1/2 a second)

### START push-piece:

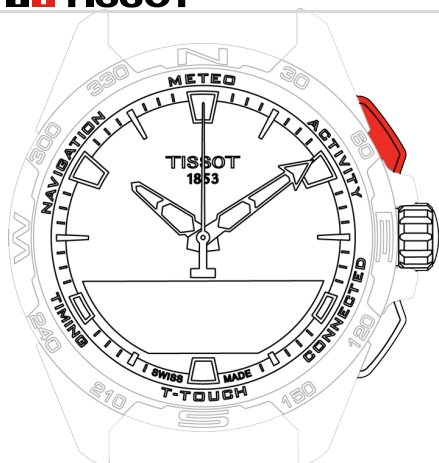

Short press: start or stop the timer / countdown

 /  : Long press: lock/unlock the watch

**BACK push-piece:**

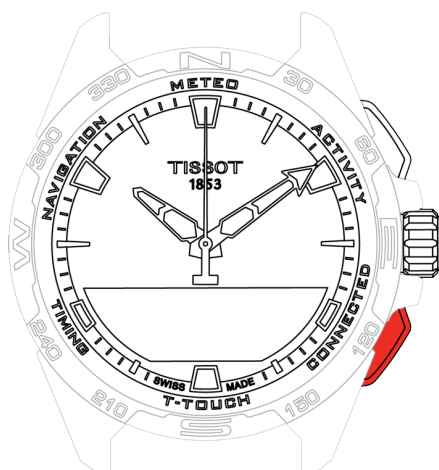

- Long press: go back to the main menu
- Short press: reset the timer/ countdown
- Short press: cancel a setting/ reject an incoming call/ stop an alarm/ go back to the previous screen or exit a mode

**Crown:**

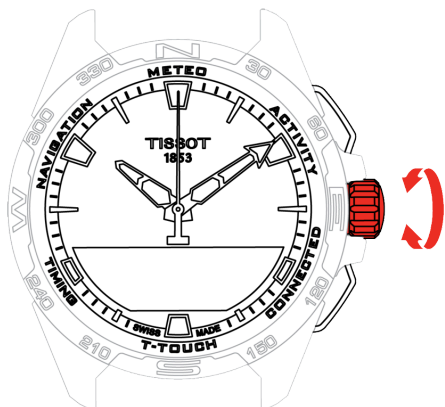









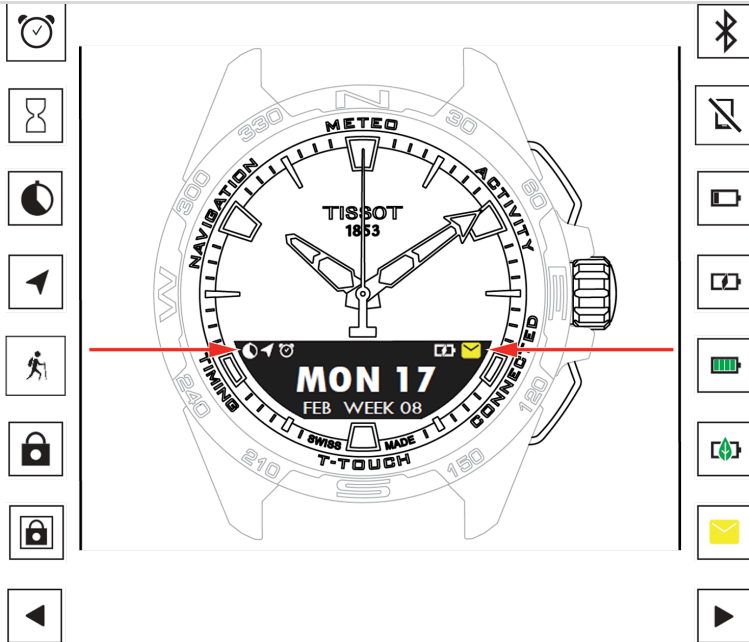



- Rotation: navigate / scroll through functions and menus / change a value
- Long press: activate screen backlighting
- Short press: confirm/ enter a sub-menu/ snooze an alarm/ stop the alarm sounding during an incoming call





**! INFO**

Note: All touch actions can be performed by using the push-pieces and the crown instead.

To activate the functions on your T-Touch Connect Solar a gentle press on the push-buttons or touch on the glass is all that is required. Excessive force can damage the watch.



-  One or more alarms active
-  Countdown in progress
-  Timer running
-  Navigation in progress
-  Activity in progress
-  Watch locked
-  Watch locked in secure mode (password)
-  Screen available on left
-  Bluetooth® activated
-  Watch disconnected
-  Battery low

-  Battery charging
-  Battery charged
-  Watch in Eco mode
-  Unread notifications
-  Screen available on right

## Reset the password with a smartphone

If you have forgotten the password and the watch is locked, it can be reset using the T-Touch Connect Solar app as per the procedure below:

- The watch is paired with and connected to a smartphone.

1. Open the "PARAMETERS" tab using the app.
2. Press the "My watch" menu.
3. Then under "CONFIGURATION", press "Watch password".
4. Press the "RESET PASSWORD" button.

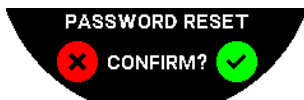

5. On the T-Touch Connect Solar MIP screen, confirm the reset action.

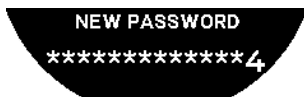

6. Use the touch zones to create your new password.
  - Each zone corresponds to a character: 0, 2, 4, C, 6, 8 and X.
  - NB: minimum 6 digits, maximum 14.

7. When you have entered the code, confirm with the crown.

- You can go back to the previous screen at any point by using the BACK push-piece.

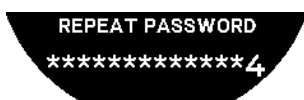

8. Repeat and confirm the new password by pressing the crown.

## Resetting the password from the watch

If you have forgotten the password and the watch is locked, it can be reset using the T-Touch Connect Solar watch as per the procedure below:

- The watch is locked by a password.

1. Press and hold the START push-piece;



- The T-Touch Connect Solar's MIP screen displays the screen above.

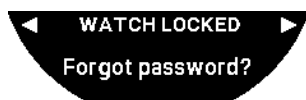

2. Turn the crown to scroll through the "Forgot password?" menu.

3. Confirm with the crown to perform the resetting procedure.

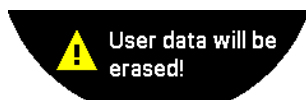

4. Press the crown.



5. Confirm to restore the watch to factory settings.

- The watch will be reset and will restart. It will no longer be recognised in the smartphone's app.

6. Open the "PARAMETERS" tab using the app.

7. Press the "My watch" menu.

8. Then under "CONFIGURATION", press the "REMOVE WATCH" button to delete the watch's settings from the smartphone.

- For iOS, remove the watch from the phone's list of Bluetooth® peripherals.

9. Confirm the pop-ups to finish deleting the settings from the app.

After the watch's settings have been removed from the smartphone T-Touch Connect Solar app, the pairing procedure between the watch and app needs to be repeated, to enable them to communicate with each other again, see [Using the T-Touch Connect Solar paired with a smartphone](#).



## Compatibility

The T-Touch Connect Solar is equipped with a Bluetooth® function, and requires the use of a smartphone meeting the following requirements:

Android requirements	Operating system 9.0 or later. This system version has been available since 7 March 2018. Most devices manufactured after this date will meet this requirement.
Apple iOS requirements	iOS 16 or later. Compatible with iPhone available since September 2022.
Huawei requirements	HarmonyOS 2.0 or later. Available for some Huawei smartphones from June 2021.

Tissot ensures that its products are compatible with Android mobile devices, the best known and most widely-used worldwide. Some devices, however, are not compatible with the T-Touch Connect Solar:

- Xiaomi Mi 8 lite international version;
- Blackberry Key2 LE;
- Samsung A21S;
- Sony XZ3;
- Caterpillar S60.

The T-Touch Connect Solar app is only supported in the following countries and languages:

<b>Supported countries</b>	<b>Supported character sets (notifications)</b>	<b>App languages</b>	<b>Watch languages</b>
Albania	Afrikaans	German	German
Germany	Albanian	English	English

<b>Supported countries</b>	<b>Supported character sets (notifications)</b>	<b>App languages</b>	<b>Watch languages</b>
Andorra	German	Chinese (simplified)	Chinese (simplified)
Australia	English	Chinese (traditional)	Korean
Austria	Basque	Korean	Spanish
Belarus	Breton	Danish	French
Bosnia and Herzegovina	Catalan*	Spanish	Italian
Belgium	Chinese (simplified)	Finnish	Japanese
Bulgaria	Korean	French	Russian
Canada	Corsican	Italian	
Chile	Danish*	Japanese	
China	Scots	Dutch	
Cyprus	Spanish	Norwegian	
Colombia	Estonian*	Polish	
Korea	Faroese	Portuguese	
Croatia	Finnish*	Romanian	
Denmark	French	Swedish	
United Arab Emirates	Scottish Gaelic		
Spain	Galician		

Supported countries	Supported character sets (notifications)	App languages	Watch languages
Estonia	Welsh*		
USA	Hungarian*		
Finnish	Indonesian		
France	Irish		
Gibraltar	Irish Gaelic* (traditional spelling)		
Greece	Icelandic		
Greenland	Italian		
Hong Kong	Japanese		
Hungary	Kurdish		
Faroe Islands	Leonese		
Ireland	Lithuanian		
Iceland	Luxembourgish		
Israel	Malay		
Italy	Manx		
Japan	Dutch*		
Jordan	Norwegian		
Kosovo	Occitan		
Latvia	Polish		

Supported countries	Supported character sets (notifications)	App languages	Watch languages
Liechtenstein	Portuguese		
Lithuania	Rhaeto-Romanic		
Luxembourg	Southern Sami		
Macao	Slovak		
North Macedonia	Swedish		
Malta	Swahili		
Mexico	Tagalog		
Moldova	Czech		
Monaco	Walloon		
Montenegro			
Norway			
New Zealand			
Netherlands			
Poland			
Portugal			
Czech Republic			
Romania			
United Kingdom			
San Marino			

Supported countries	Supported character sets (notifications)	App languages	Watch languages
Serbia			
Singapore			
Slovakia			
Slovenia			
Sweden			
Switzerland			
Taiwan			
Turkey			
Ukraine			
Vatican City			

**! INFO**

Please note that some characters may be missing.



## Versions and new features

Version	Availability	Modifications
7.3	November 2023	IMPROVEMENTS AND BUG FIXES
6.2	February 2023	BRING ME BACK The watch guides the user back to their start point, following the waypoints along the recorded track (in reverse order). The user can choose between two modes for the "BRING ME BACK" function: Linear or Waypoints. MULTI-REGION The watch is now available in Korean. IMPROVEMENTS Watch password question removed. If GNSS data quality is insufficient or unavailable, the watch informs the user that it is no longer saving waypoints. If there are any missing GNSS data points for any reason, the distance during the corresponding time interval is calculated based on the step counter. The hands can be moved out of the display by briefly pressing on the T0 push-button when the watch is locked. IMPROVEMENTS AND BUG FIXES
6.1	November 2022	IMPROVEMENTS AND BUG FIXES
6.0	July 2022	ACTIVITY - GPS LOCATION You can now register outdoor activities with GPS tracking. Execute the new function from your watch, and find the route taken in the app. ACTIVITY - BRING ME BACK During an activity, the watch guides the user back to the start point using GPS and the compass. ALTIMETER The watch automatically calibrates the altitude twice per day. PASSWORD Addition of watch password resetting procedure either from the app or the watch. IMPROVEMENTS AND BUG FIXES
5.2	February 2022	IMPROVEMENTS AND BUG FIXES

Version	Availability	Modifications
5.0	November 2021	<p><b>OUTDOOR TRACKER</b> Addition of the differential altitude meter: displays the cumulative altitude gains and losses and average vertical ascent and descent speeds. <b>NBA</b> The results of your favourite team's match are shared in real time on your watch. <b>MULTI-REGION</b> New translation of the watch into Japanese.</p>
4.1	August 2021	<p><b>OUTDOOR TRACKER</b> The user can save their tracking data when carrying out an outdoor activity with the watch: The activity time, number of steps, number of calories and current altitude <b>CYCLING APP NOTIFICATIONS</b> The third-party cycling app notifications are displayed with a specific icon</p>
4.0	June 2021	<p><b>USER INTERFACE IMPROVEMENT</b> Based on our customers' feedback: - Dashboard redesigned with new widgets and merged with the "My watch" page - After an update, advantages of the new watch or app version displayed - Alarm and time zones modification simplified - Watch battery level and watch custom time displayed in the app <b>NBA WIDGET</b> - The fixtures for your favourite team, with the option of adding a match to your smartphone's calendar - All standings for the current season (by conference, by division) and the Playoffs - Team scores and statistics - You can decide to follow another team at any time - The next game and last game are also displayed on your watch <b>MULTI-REGION</b> New application translation (Danish, Dutch, Finnish, Norwegian, Polish, Portuguese and Swedish) <b>IMPROVEMENTS AND BUG FIXES</b> Improvements and bug fixes for an enhanced user experience</p>
3.1	Mar. 2021	<p><b>MULTI-LANGUAGE:</b> The watch is available in English, French, German, Italian, Spanish or Chinese. <b>MULTI-REGION:</b> User data for Chinese residents is stored in China. <b>NOTIFICATIONS:</b> The user can scroll through their notification lines by turning the crown. <b>WATCH:</b> There is a bigger connection range between the watch and phone.</p>

<b>Version</b>	<b>Availability</b>	<b>Modifications</b>
		<p>BAROMETER: In addition to the hands, the weather trend is displayed by an appropriate icon.</p>
2.0	Dec. 2020	<p>TIMER: manage a list of countdowns in the app, and start directly from the app            FIND MY PHONE: a new phone locating function, running on the watch            FIND MY WATCH: a new watch locating function, running on the phone            ENERGY: a detailed display of the battery level and solar charge level in the watch's "QUICK SETTINGS"            NOTIFICATIONS: A new function enabling you to clear all notifications            PAIRING: Simplified pairing procedure: the mobile app detects the closest watch to establish the link.            SOUND &amp; VIBRATION: Separate sound and vibration setting added for notifications            CONNECTION: improved reconnection after the phone has been out of range for several hours.</p>
1.1	Sept. 2020	Basic product version

## Documents

### Documents about this

- [Warranty](#)
- [Declaration of Conformity \(Wireless Charger\)](#)
- [Declaration of Conformity](#)